



KONICA MINOLTA

Spectrophotometer CM-25cG

New standard model for color and gloss measurement !



The two-in-one model that can simultaneously measure both color and gloss !



High inter-instrument-agreement !



High repeatability and user friendliness!



The spectrophotometer CM-25cG is a two-in-one model for simultaneous color and gloss measurement.

Changeable apertures allow easy measurements of small objects.

Color: Ø8 mm / Ø3 mm

Gloss: Ø10 mm / Ø3 mm

New! (from December, 2017)

DIN 99o has been added as a new color-difference formula commonly used in automotive industry.

Display examples

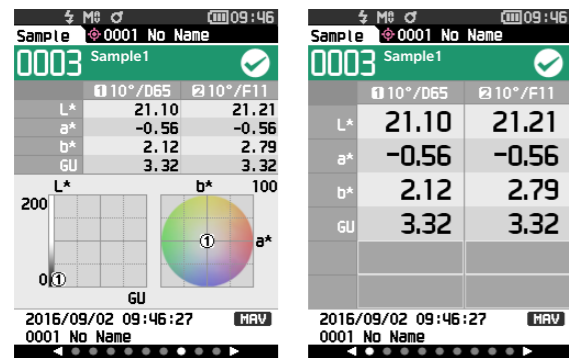

The 2.7-inch TFT color LCD makes measurements easy to read, and the easy-to-understand GUI provides high usability.

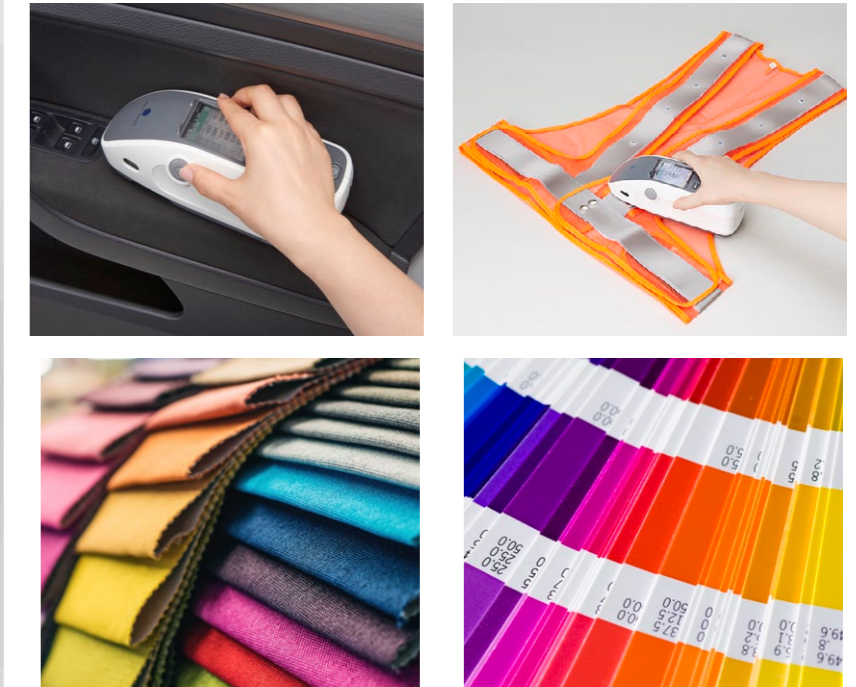

A two-in-one model for color and gloss



The CM-25cG greatly improves work efficiency by eliminating the need to switch between two instruments — one for color, one for gloss — for each measurement, thus reducing takt time, and providing color and gloss data from exactly the same measurement point for more accurate quality control.

High inter-instrument agreement



The CM-25cG offers high inter-instrument agreement of within $\Delta E^* 0.15$ (typical) (MAV) for color and ± 0.2 GU for gloss measurements of 1 to 10 GU. This high inter-instrument agreement enables digital data management for more efficient quality control among your factories or between your company and your partners.

High repeatability and user friendliness

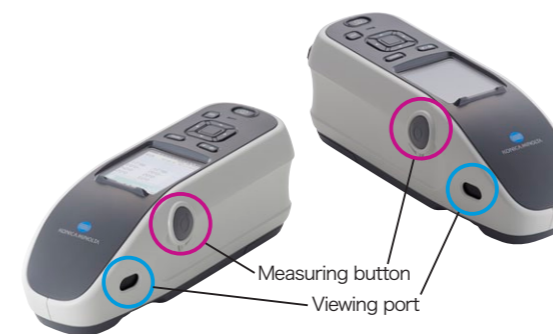

By using a 45°:0° illumination/viewing system with ring-shaped illumination having light sources radially located at certain intervals, the CM-25cG provides stable data while minimizing instrument rotational effects. The system also provides data with high accuracy and repeatability even if there is a small gap between the measurement aperture and the subject.

Other features include high-speed measurement, cable-free operation, and viewing ports and measuring buttons on both the right and left sides of the instrument body for easy operation and high measurement stability in any situation.

* Level of subject visibility through viewing port depends on measurement subject.

SpectraMagic NX (Option) Ver. 2.8 or later

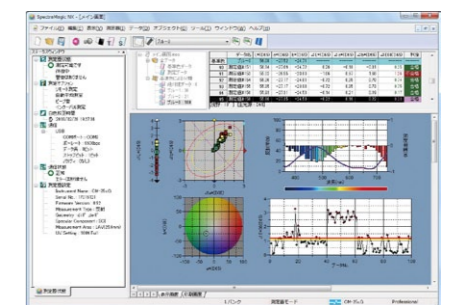

OS : Windows® 7 Professional 32 bit, 64 bit; Windows® 8.1 Pro 32 bit, 64 bit; Windows® 10 Pro 32 bit, 64 bit
 • The hardware of the computer system to be used must meet or exceed the greater of the recommended system requirements for the compatible OS being used or the following specifications.

CPU : Pentium® III 600 MHz equivalent or faster
 Memory : 128 MB or more (256 MB or more recommended)
 Hard disk : 450 MB or more of free space for installation
 Display : Resolution: 1,024 x 768 dots or more/ 16-bit colors or more
 Other : DVD-ROM drive (required for installation); one free USB port for protection key; one free port (serial port or additional USB port) for connection to instrument when connecting via cable (or USB port for USB Bluetooth® adapter when using a USB Bluetooth® adapter for performing communication with CM-25cG via Bluetooth®); Internet Explorer Version. 5.01 or later.

• Windows® is a trademark or registered trademark of Microsoft Corporation in the USA and other countries.
 • Pentium® is a trademark of Intel Corporation in the USA and other countries.
 • The specifications given here are subject to change without prior notice.
 • Bluetooth® is a registered trademark of Bluetooth SIG, Inc. and is used under license agreement.

Main Specifications

Model	Spectrophotometer CM-25cG
Illumination/viewing system	45°c:0°
Detector	Dual 40-element silicon photodiode arrays
Spectral separation device	Planar diffraction grating
Wavelength range	360-740 nm
Wavelength pitch	10 nm
Half bandwidth	Approx. 10 nm
Measurement range	0-175 %; Output/display resolution : 0.01 %
Light source	Pulsed xenon lamp
Measurement/illumination area	MAV: Ø8 mm/12×16 mm, SAV: Ø3 mm/12×16 mm
Repeatability	Chromaticity value: Standard deviation within ΔE^*ab 0.04 (When a white calibration plate is measured 30 times at 10-second intervals after white calibration)
Inter-instrument agreement	Within ΔE^*ab 0.15 (MAV) (Average for 12 BCRA Series II color tiles compared to values measured with a master body under Konica Minolta standard measurement conditions)
Observer	2° or 10° Standard Observer
Illuminant	A, C, D50, D65, F2, F6, F7, F8, F10, F11, F12, ID50, ID65, User illuminant (simultaneous evaluation with two illuminants possible)
Displayed data	Spectral values/graph, colorimetric values/graph, color-difference values/graph, pass/fail judgement, pseudocolor
Colorimetric data	L*a*b*, L*C*h, Hunter Lab, Yxy, XYZ, and color differences in these spaces; Munsell
Indexes	MI, WI (ASTM E313), YI (ASTM E313, ASTM D1925), ISO Brightness (ISO2470), WI/Tint (CIE)
Color-difference formula	ΔE^*ab (CIE 1976), ΔE^*94 (CIE 1994), $\Delta E00$ (CIE DE2000), CMC (l:c), ΔE (Hunter), $\Delta E99a$ (DIN 99a)
Standard compliance	CIE No. 15, ISO 7724/1, ASTM E179, DIN 5033 part7, JIS Z8722
Measurement geometry	60°
Light source	LED
Detector	Silicon photo diode
Measurement range	0-200 GU; Output/display resolution : 0.01 GU
Measurement area	MAV: Ø10 mm, SAV: Ø3 mm
Repeatability	0-10 GU : 0.1 GU 10-100 GU : 0.2 GU >100 GU : 0.2 % of displayed value (Standard deviation. Under Konica Minolta standard measurement conditions)
Inter-instrument agreement	0-10 GU : ±0.2 GU 10-100 GU : ±0.5 GU (MAV. Compared to values measured with a master body under Konica Minolta standard measurement conditions)
Standard compliance	JIS Z8741, JIS K5600, ISO 2813, ISO 7668, ASTM D523-08, ASTM D2457-13, DIN 67530
Measurement time	Approx. 1 seconds (to data display/output)
Minimum measurement interval	Approx. 2 seconds
Battery performance	Approx. 3,000 measurements/charge (Stand-alone measurement at 10-second intervals at 23°C) Approx. 1,000 measurements/charge (When using Bluetooth® communication)
Displayed languages	Japanese, English, German, French, Italian, Spanish, Chinese (Simplified), Portuguese, Russian, Turkish, Polish
Display	2.7-inch TFT color LCD
Interfaces	USB 2.0; Bluetooth (SPP compatible. Using optional Bluetooth Module)
Data memory	Target data: 2,500 measurements; Sample data: 7,500 measurements
Power	Rechargeable lithium-ion battery, USB bus power
Charging time	Approx. 6 hours when no charge remains
Operation temperature/humidity range	5-40 °C, relative humidity is 80% or less (at 35°C) with no condensation
Storage temperature/humidity range	0-45 °C, relative humidity is 80% or less (at 35°C) with no condensation
Size (W x H x D)	Approx. 81 x 81 x 224 mm
Weight	Approx. 600 g (Including battery)

System Diagram

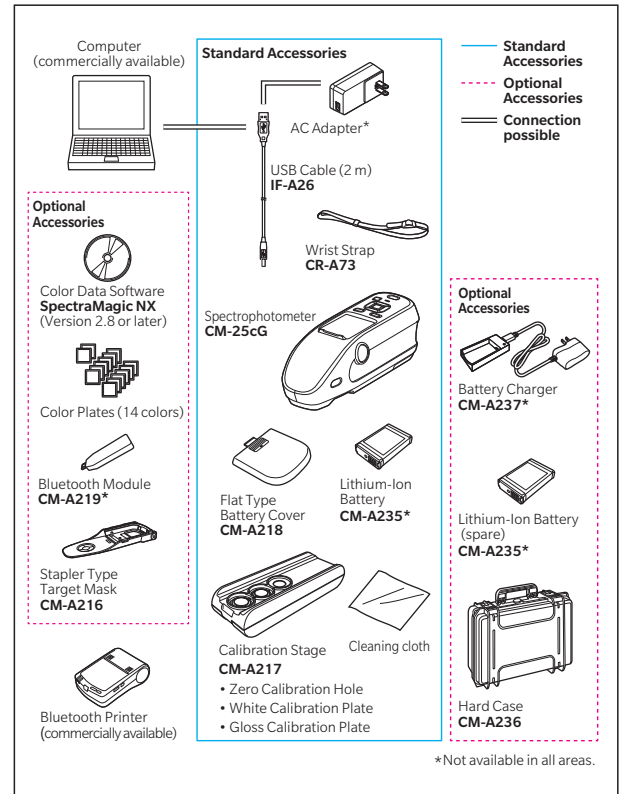

Dimensions (Units : mm)

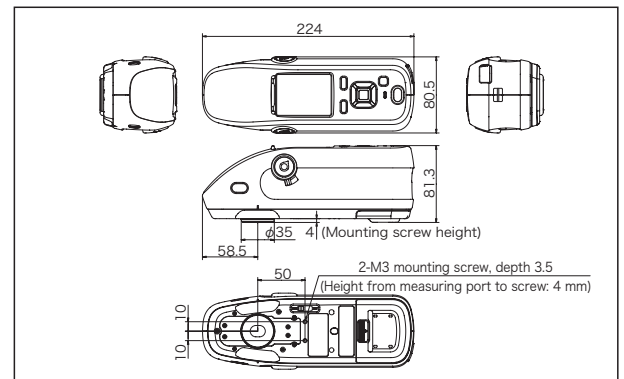

- KONICA MINOLTA, the Konica Minolta logo and symbol mark, "Giving Shape to Ideas" and SpectraMagic are registered trademarks or trademarks of Konica Minolta, Inc.
- Bluetooth® is a registered trademark of Bluetooth SIG, Inc. and is used under license agreement.
- Displays shown are for illustration purpose only.
- The specifications and appearance shown herein are subject to change without notice.



SAFETY PRECAUTIONS

For correct use and for your safety, be sure to read the instruction manual before using the instrument.

- Always connect the instrument to the specified power supply voltage. Improper connection may cause a fire or electric shock.
- Be sure to use the specified batteries. Using improper batteries may cause a fire or electric shock.

KONICA MINOLTA, INC.
Konica Minolta Sensing Americas, Inc.
Konica Minolta Sensing Europe B.V.

Osaka, Japan
New Jersey, U.S.A.
European Headquarter /BENELUX
German Office
French Office
UK Office
Italian Office
Swiss Office
Nordic Office
Polish Office
Turkish Office
SE Sales Division
Beijing Office
Guangzhou Office
Chongqing Office
Qingdao Office
Wuhan Office

Konica Minolta (CHINA) Investment Ltd.

Konica Minolta Sensing Singapore Pte Ltd.
Konica Minolta Sensing Korea Co., Ltd.

Addresses and telephone/fax numbers are subject to change without notice. For the latest contact information, please refer to the KONICA MINOLTA Worldwide Offices web page :

Phone : 888-473-2656 (in USA), 201-236-4300 (outside USA)

Nieuwegein, Netherlands **Phone** : +31 (0) 30 248-1193
München, Germany **Phone** : +49 (0) 89 4357 156 0
Roissy CDG, France **Phone** : +33 (0) 1 80 11 10 70
Warrington, United Kingdom **Phone** : +44 (0) 1925 467300
Cinisello Balsamo, Italy **Phone** : +39 02849488.00
Dietikon, Switzerland **Phone** : +41 (0) 43 322-9800
Västra Frölunda, Sweden **Phone** : +46 (0) 31 7099464
Wrocław, Poland **Phone** : +48 (0) 71 73452-11
Istanbul, Turkey **Phone** : +90 (0) 216-528 56 56
Shanghai, China **Phone** : +86- (0)21-5489 0202
Beijing, China **Phone** : +86- (0)10-8522 1551
Guangdong, China **Phone** : +86- (0)20-3826 4220
Chongqing, China **Phone** : +86- (0)23-6773 4988
Shandong, China **Phone** : +86- (0)532-8079 1871
Hubei, China **Phone** : +86- (0)27-8544 9942
Singapore **Phone** : +65 6563-5533
Goyang-si, Korea **Phone** : +82 (0) 2-523-9726

Fax : 201-785-2482

Fax : +31 (0) 30 24 81 211
Fax : +49 (0) 89 4357 156 99
Fax : +33 (0) 1 80 11 10 82
Fax : +44 (0) 1925 711143
Fax : +39 02849488.30
Fax : +41 (0) 43 322-9809

Fax : +48 (0) 71 734 52 10
Fax : +90 (0) 212-253 49 69
Fax : +86- (0)21-5489 0005
Fax : +86- (0)10-8522 1241
Fax : +86- (0)20-3826 4223
Fax : +86- (0)23-6773 4799
Fax : +86- (0)532-8079 1873
Fax : +86- (0)27-8544 9991
Fax : +65 6560-9721
Fax : +82 (0) 31-995-6511

<https://konicaminolta.com/instruments/network>